

創造的で革新的、また挑戦的な若い企業

A creative, innovative and challenging young company

低圧誘導電動機

Low Voltage Induction Motor





CEO Message



世界最高の品質と競争力を備えた強い企業、 IK ELECTRIC

IK ELECTRICは国際規格の外観が守られ、
小型・軽量化された電動機を
競争力のある価格で供給しています。

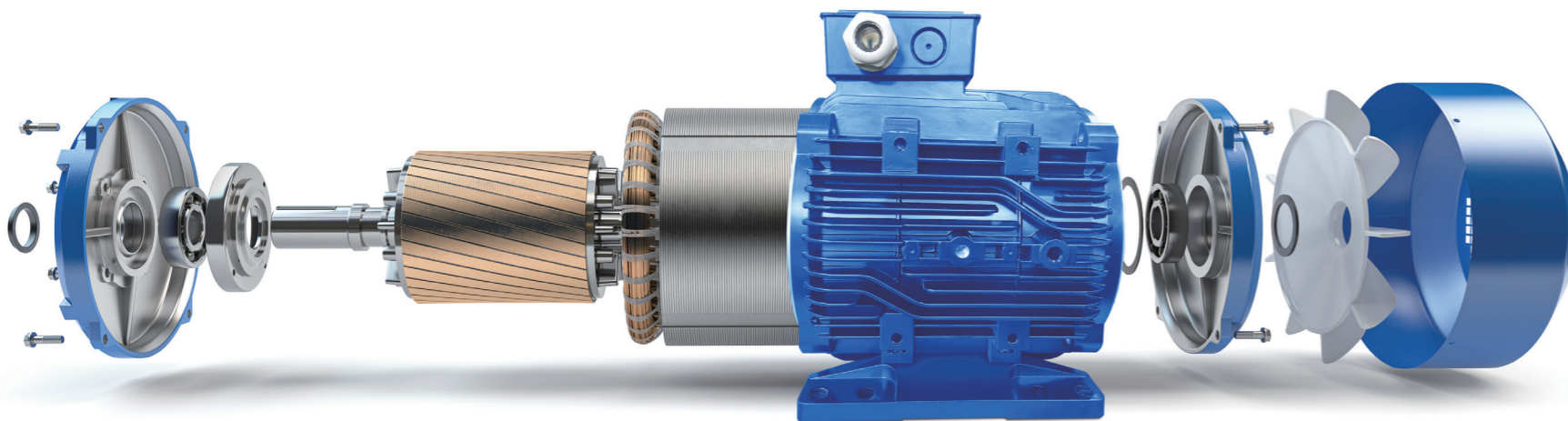

創造的な革新と挑戦的な若い企業、 半世紀にわたり、ノウハウと技術力でお客様を感動させる IK ELECTRIC

韓国電動機産業の歴史と共に越えてきた弊社は、従来の顧客カスタマイズ型電動機だけでなく、IEC、NEMAなどの国際規格に準拠した標準型電動機を生産しており、弊社が作った製品は小さく軽量で、外観が非常に美しく、価格競争力があります。

一歩先に進むのは本当に簡単ではないことですが、弊社はこれを実現するために絶え間なく人材投資と設備投資をしております。

これまで設計ソフトウェアと最先端電動機性能測定システム（ダイナモメタ）、そしてデジタル無負荷総合試験機など最先端設備を基盤に最適な電動機を設計して最高品質を維持しており、2022年からスマート工場を導入を通じた生産性改善で、より競争力のある製品を提供できるよう努めています。

弊社はこれからもお客様の信頼に基づいて最高の人材が集まって、顧客に最高の品質製品とサービスを提供するグローバル企業になるように最善の努力を尽くすことを約束致します。
顧客皆様の継続的な関心と惜しみないご支援をお願いいたします。

ありがとうございます。

History

1979

・会社設立
(ソウル特別市城東区)

1989

・電気用品型式承認

1997

・工場新築移転
(仁川市西区)

1985

・1種電気用品
製造業登録

1990

・工場新築移転
(京畿道富川市)

1998

・韓国産業標準
(K)製品認証

2018

・新型AL Frame開発
・プレミアム(IE3)認証

2020

・電気種CE認証

2008

・工場新築移転
(京畿道華城市)

2019

・企業付設研究所設立
・ISO認証
・技術革新中小企業
(Inno-Biz)

2022

・相互変更
(日光モーター→IK ELECTRIC)
・UL認証

Contents

01	製品特徴	06
02	三相プレミアム誘導電動機	09
	・ B3 Horizontal Type	
	・ B5 Vertical Type	
	・ B35 Horizontal-Vertical Type	
	・ B14 C-Face Type	
	・ B34 Horizontal C-Face Type	
03	単相誘導電動機 (全閉型)	15
	・ コンデンサ運転型またはコンデンサ起動&運転型 Type : B3/ B5/ B35/ B14/ B34	
04	油圧用誘導電動機	22
	・ 三相プレミアム誘導電動機	
	・ 単相誘導電動機	
05	オンデマンド誘導電動機	28
	・ 単相誘導電動機 (半閉型)	
	・ ポンプ用	
	・ 減速機用	
	・ 空調、ファン、送風機用	
	・ 産業機械用	
	・ NEMA標準	
06	送風機	31
	・ 遠心型高圧送風機	
	・ 遠心型ターボ送風機	
07	結線図/重量	33
08	主な証明書	34

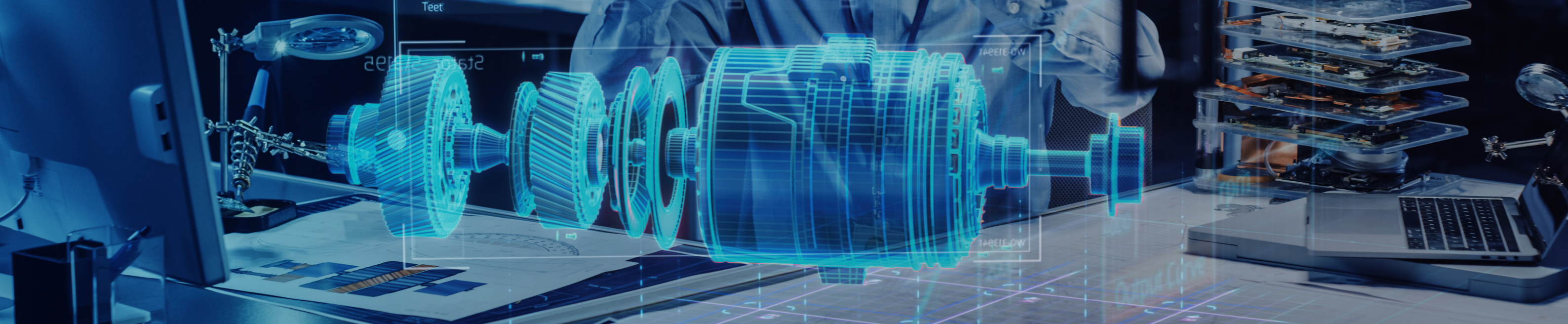

01 製品特徴



見事な外観

- ・アルミダイカストフレーム使用で外観がスリムで小型・軽量化を実現
- ・フレーム冷却フィンの差別化されたAir Flow Technologyを適用して曲線美を活かし、冷却効果を最大化



品質認証

- ・国内初のKS C 4202 三相プレミアム[Ⓜ] 範囲認証
- ・KS C 4204 単相[Ⓜ] 誘導電動機範囲認証
- ・全モデルCE認証
- ・UL認証



高品質

- ・最先端ソフトウェアを活用した最適化設計で高品質特性を維持
- ・最新の電動機性能測定システム(Dynamo sys.)を活用した性能および耐久性試験
- ・部品の社内加工及び熟練した組立で低騒音・低振動実現

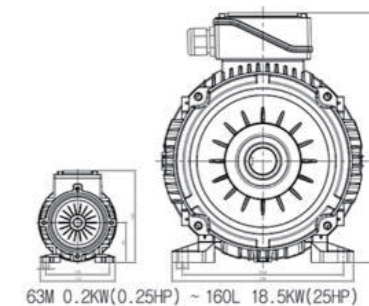

様々な機種

- ・フレームサイズ：63~160
- ・出力：0.2~18.5kW
- ・単相および三相誘導電動機（標準、油圧、特注）
- ・取付形式：B3、B5、B35、B14、B34
- ・端子箱方向：左、右、上、前後変更可能

02

三相プレミアム誘導電動機

- ・ B3 Horizontal Type
- ・ B5 Vertical Type
- ・ B35 Horizontal-Vertical Type
- ・ B14 C-Face Type
- ・ B34 Horizontal C-Face Type

IE3 | 三相プレミアム 誘導電動機

B3 Horizontal types



Dimensional drawings

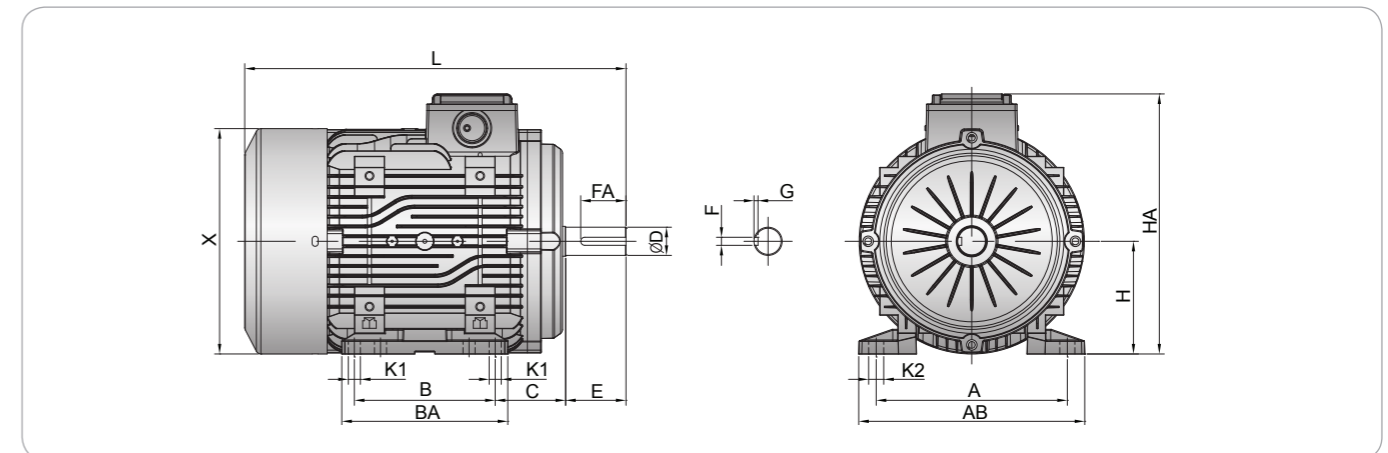

Dimensions

Frame Size	Output (kW)				Dimension(mm)																Bearings	
					Overall					DE Shaft extension					Base							
	2P	4P	6P	8P	H	C	L	HA	X	D	E	F	FA	G	A	B	AB	BA	K1	K2	DE	ODE
63M	0.2	0.2			63	40	206	145	124	11	23	4	20	2.5	100	80	118	100	7	10	6202	6202
	0.4	0.4			71	45	237	169	142	14	30	5	25	3	112	90	130	105	7	10	6203	6202
80M	*0.55				80	50	266	189	159	19	40	6	30	3.5	125	100	149	130	10	15	6204	6203
	*0.55	0.4	0.2																			
	0.75	0.75																				
	*0.9																					
90L	1.5	*1.1	0.75	0.4	90	56	324	212	180	24	50	8	45	4	140	125	169	145	10	15	6205	6204
	2.2	1.5																				
100L		2.2	1.5	0.75	100	63	360	228	196	28	60	8	45	4	160	140	190	165	12	15	6206	6205
	*3																					
112M		*2.2	2.2	1.5	112	70	378	259	222	28	60	8	45	4	190	140	225	165	12	15	6206	6205
	3.7	3.7																				
132S	5.5	5.5	3.7	2.2	132	89	473	294	263	38	80	10	65	5	216	140	248	215	13	15	6308	6307
	7.5																					
132M		7.5	5.5	3.7												178						
160M	11				160	108	622.5	394	312.4	42	110	12	90	5	254	210	286	290	15	18	6309	6309
	15	11	7.5	5.5																		
160L	18.5	15	11	7.5											254							

- Note**
1. 上記の仕様は、品質と性能を向上させるために予告なく変更されることがあります。
 2. *表示はIEC/KS規格品ではありません。

IE3 | 三相プレミアム誘導電動機

B5 Vertical types



Dimensional drawings

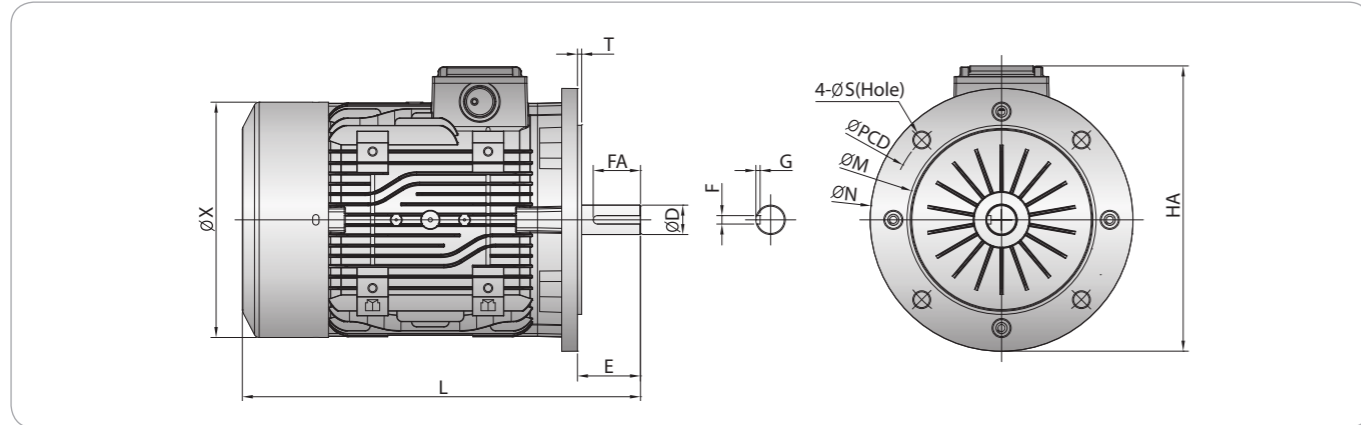

Dimensions

Frame Size	Output (kW)				Dimension(mm)														Bearings	
					Overall								DE Shaft extension							
	2P	4P	6P	8P	S(Hole)	PCD	M	N	HA	L	X	T	D	E	F	FA	G	DE	ODE	
63M	0.2	0.2			10	115	95	140	145	206	124	3	11	23	4	20	2.5	6202	6202	
71M	0.4	0.4			10	130	110	160	178	237	142	3	14	30	5	25	3	6203	6202	
	*0.55																			
80M		*0.55	0.4	0.2	12	165	130	200	212	266	160	3.5	19	40	6	30	3.5	6204	6203	
	0.75	0.75																		
	*0.9																			
	*1.1																			
90L	1.5	*1.1	0.75	0.4	12	165	130	200	222	324	180	4	24	50	8	45	4	6205	6204	
	2.2	1.5																		
100L		2.2	1.5	0.75	15	215	180	250	253	360	196	4	28	60	8	45	4	6206	6205	
	*3																			
112M		*2.2	2.2	1.5	15	215	180	250	272	378	232	4	28	60	8	45	4	6206	6205	
	3.7	3.7																		
132S	5.5	5.5	3.7	2.2	15	265	230	300	312	473	263	4	38	80	10	65	5	6308	6307	
	7.5																			
132M		7.5	5.5	3.7	19	300	250	350	350	507	263	5	42	110	12	90	5	6309	6308	
	*11																			
160M	11				19	300	250	350	409	622.5	312.4	5	42	110	12	90	5	6309	6309	
	15	11	7.5	5.5																
160L	18.5	15	11	7.5																

Note | 1. 上記の仕様は、品質と性能を向上させるために予告なく変更されることがあります。
2. *表示はIEC/KS規格品ではありません。

IE3 | 三相プレミアム誘導電動機

B35 Horizontal Vertical types



Dimensional drawings

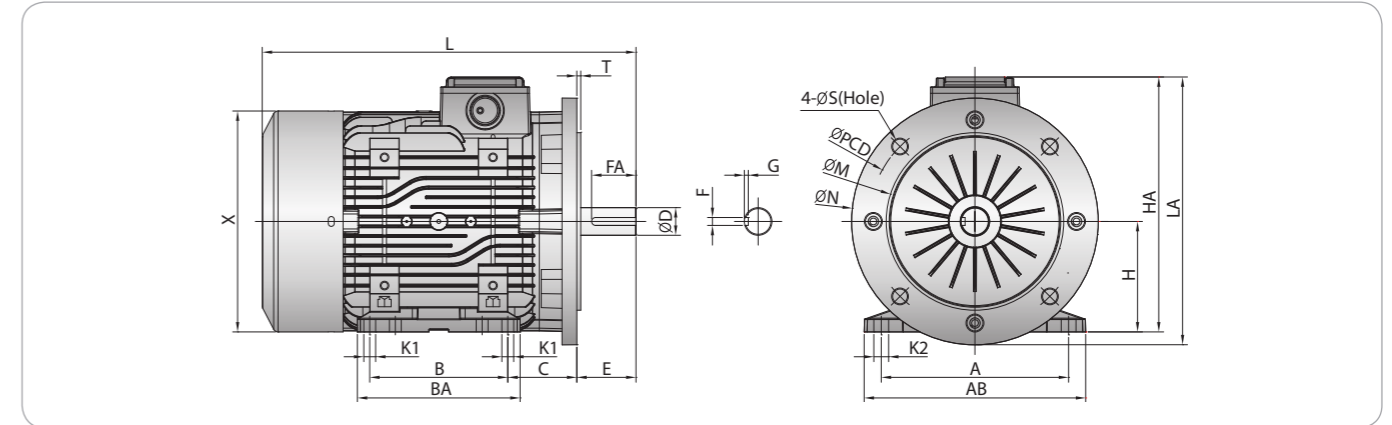

Dimensions

Frame Size	Output (kW)				Dimension(mm)																		Bearings					
					Overall								DE Shaft extension						Base									
	2P	4P	6P	8P	S(Hole)	PCD	M	N	H	C	HA	LA	L	X	T	D	E	F	FA	G	A	B	AB	BA	K1	K2	DE	ODE
63M	0.2	0.2			10	115	95	140	63	40	145	152	206	124	3	11	23	4	20	2.5	100	80	118	100	7	10	6202	6202
71M	0.4	0.4			10	130	110	160	71	45	169	178	237	142	3	14	30	5	25	3	112	90	130	105	7	10	6203	6202
	*0.55																											
80M		*0.55	0.4	0.2	12	165	130	200	80	50	189	209	266	160	3.5	19	40	6	30	3.5	125	100	149	130	10	15	6204	6203
	0.75	0.75																										
	*0.9																											
	*1.1																											
90L	1.5	*1.1	0.75	0.4	12	165	130	200	90	56	212	222	324	180	4	24	50	8	45	4	140	125	169	145	10	15	6205	6204
	2.2	1.5																										
100L		2.2	1.5	0.75	15	215	180	250	100	63	228	253	360	196	4	28	60	8	45	4	160	140	190	165	12	15	6206	6205
	*3																											
112M		*2.2	2.2	1.5	15	215	180	250	112	70	259	272	378	222	4	28	60	8	45	4	190	140	225	165	12	15	6206	6205
	3.7	3.7																										
132S	5.5	5.5	3.7	2.2	15	265	230	300	132	89	294	312	473	263	4	38	80	10	65	5	216	140	248	215	13	15	6308	6307
	7.5																											
132M		7.5	5.5	3.7	19	300	250	350	132	89	294	350	503	263	5	42	110	12	90	5	216	178	248	215	13	15	6309	6308
	*11																											
160M	11				19	300	250	350	160	108	394	409	622.5	312.4	5	42	110	12	90	5	254	210	286	290	15	18	6309	6309
	15	11	7.5	5.5																								
160L	18.5	15	11	7.5																								

Note | 1. 上記の仕様は、品質と性能を向上させるために予告なく変更されることがあります。
2. *表示はIEC/KS規格品ではありません。

IE3 | 三相プレミアム誘導電動機

B14 C-Face types



Dimensional drawings

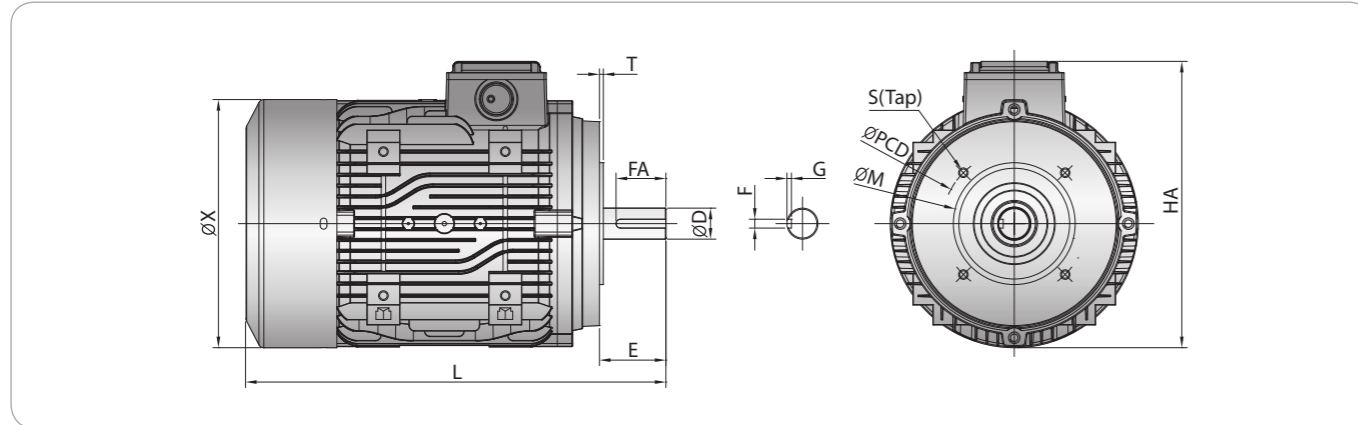

Dimensions

Frame Size	Output (kW)				Dimension(mm)													Bearings	
					Overall							DE Shaft extension							
	2P	4P	6P	8P	S(Tap)	PCD	M	HA	L	X	T	D	E	F	FA	G	DE	ODE	
63M	0.2	0.2			M5	75	60	145	206	124	3	11	23	4	20	2.5	6202	6202	
71M	0.4	0.4			M6	85	70	169	237	142	2.5	14	30	5	25	3	6203	6202	
	*0.55																		
80M		*0.55	0.4	0.2	M6	100	80	189	266	160	3	19	40	6	30	3.5	6204	6203	
	0.75	0.75																	
	*0.9																		
	*1.1																		
90L	1.5	*1.1	0.75	0.4	M8	115	95	212	324	180	3.5	24	50	8	45	4	6205	6204	
	2.2	1.5																	
100L		2.2	1.5	0.75	M8	130	110	226	360	196	3.5	28	60	8	45	4	6206	6205	
	*3																		
112M		*2.2	2.2	1.5	M8	130	110	263	378	232	3.5	28	60	8	45	4	6206	6205	
	3.7	3.7																	
132S	5.5	5.5	3.7	2.2	M10	165	130	294	473	263	3.5	38	80	10	65	5	6308	6307	
	7.5																		
132M		7.5	5.5	3.7															
160M	11				12	215	180	393	622.5	312.4	5	42	110	12	90	5	6309	6309	
	15	11	7.5	5.5															
160L	18.5	15	11	7.5															

Note | 1. 上記の仕様は、品質と性能を向上させるために予告なく変更されることがあります。
2. *表示はIEC/KS規格品ではありません。

IE3 | 三相プレミアム誘導電動機

B34 Horizontal C-Face types



Dimensional drawings

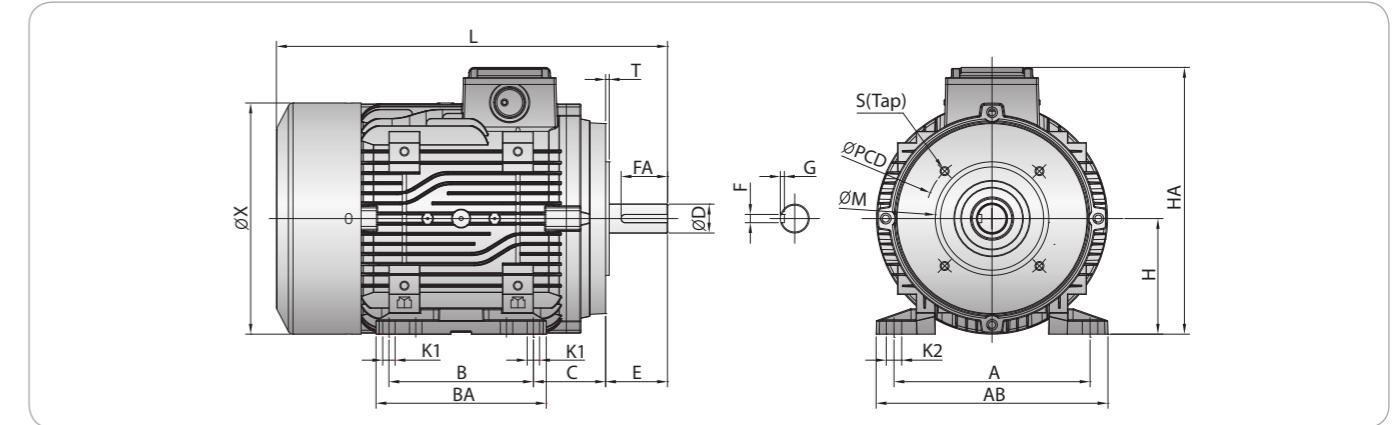

Dimensions

Frame Size	Output (kW)				Dimension(mm)													Bearings								
					Overall							DE Shaft extension								Base						
	2P	4P	6P	8P	S(Tap)	PCD	M	H	C	L	HA	X	T	D	E	F	FA	G	A	B	AB	BA	K1	K2	DE	ODE
63M					M5	75	60	63	40	206	145	124	3	11	23	4	20	2.5	100	80	118	100	7	10	6202	6202
71M	0.4	0.4			M6	85	70	71	45	237	169	142	2.5	14	30	5	25	3	112	90	130	105	7	10	6203	6202
	*0.55																									
80M		*0.55	0.4	0.2	M6	100	80	80	50	266	189	160	3	19	40	6	30	3.5	125	100	149	130	10	15	6204	6203
	0.75	0.75																								
	*0.9																									
	*1.1																									
90L	1.5	*1.1	0.75	0.4	M8	115	95	90	56	324	212	180	3.5	24	50	8	45	4	140	125	169	145	10	15	6205	6204
	2.2	1.5																								
100L		2.2	1.5	0.75	M8	130	110	100	63	360	228	196	3.5	28	60	8	45	4	160	140	190	165	12	15	6206	6205
	*3																									
112M		*2.2	2.2	1.5	M8	130	110	112	70	378	259	222	3.5	28	60	8	45	4	190	140	225	165	12	15	6206	6205
	3.7	3.7																								
132S	5.5	5.5	3.7	2.2	M10	165	130	132	89	473	294	263	3.5	38	80	10	65	5	216	140	248	215	13	15	6308	6307
	7.5																									
132M		7.5	5.5	3.7																						
160M	11				12	215	180	160	108	622.5	394	312.4	5	42	110	12	90	5	254	210	286	290	15	18	6309	6309
	15	11	7.5	5.5																						
160L	18.5	15	11	7.5																						

Note | 1. 上記の仕様は、品質と性能を向上させるために予告なく変更されることがあります。
2. *表示はIEC/KS規格品ではありません。

03

单相誘導電動機 (全閉型)

・ Condenser Running (コンデンサ運転型)

Type : B3/ B5/ B35/ B14/ B34

・ Condenser Starting & Running (コンデンサ起動&運転型)

Type : B3/ B5/ B35/ B14/ B34

单相誘導電動機 (全閉型)

コンデンサ運転型 / コンデンサ起動&運転型

B3 Horizontal types



Dimensional drawings

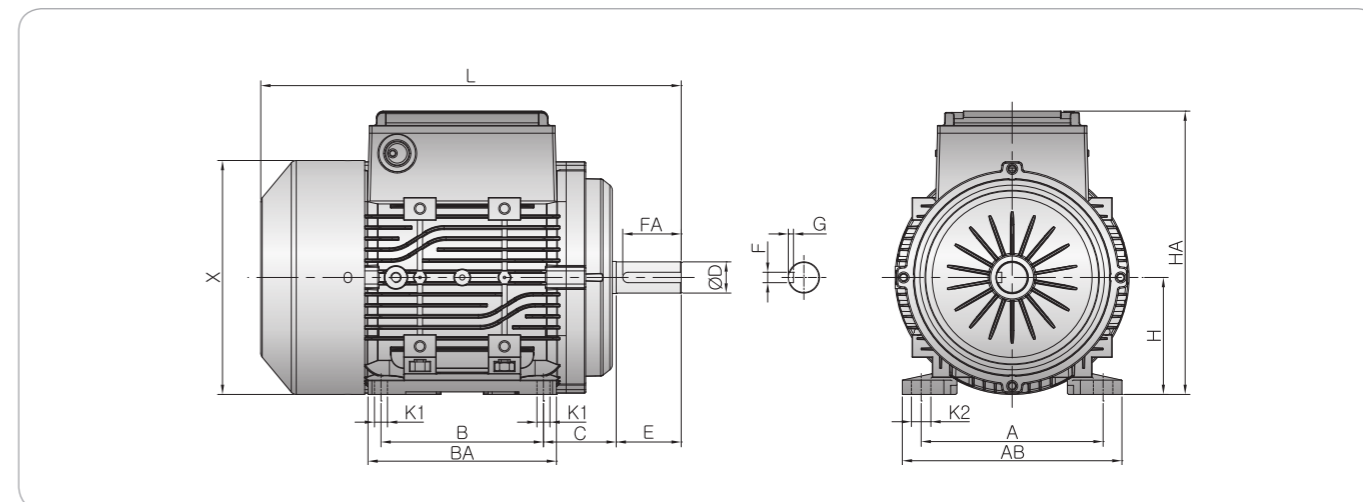

Dimensions

Frame Size	Output (kW)			Dimension(mm)																Bearings	
				Overall					DE Shaft extension					Base							
	2P	4P	6P	H	C	L	HA	X	D	E	F	FA	G	A	B	AB	BA	K1	K2	DE	ODE
71M	0.4	*0.2		71	45	237	171	142	14	30	5	25	3	112	90	130	105	7	10	6203ZZ	6202ZZ
	*0.55	0.4																			
80M			0.4	80	50	266	192	159	19	40	6	30	3.5	125	100	149	130	10	15	6204ZZ	6203ZZ
	0.75	*0.55																			
	*0.9	0.75																			
90L				90	56	324	218	180	24	50	8	45	4	140	125	169	145	10	15	6205ZZ	6204ZZ
	1.5	*0.75	0.75																		
		1.5																			
100L		2.2	1.5	100	63	360	231	196	28	60	8	45	4	160	140	190	165	12	15	6206ZZ	6205ZZ
		*3																			

Note | 1. 上記の仕様は、品質と性能を向上させるために予告なく変更されることがあります。
2. *表示はIEC/KS規格品ではありません。

单相誘導電動機 (全閉型)

コンデンサ運転型／コンデンサ起動&運転型

B5 Vertical types



Dimensional drawings

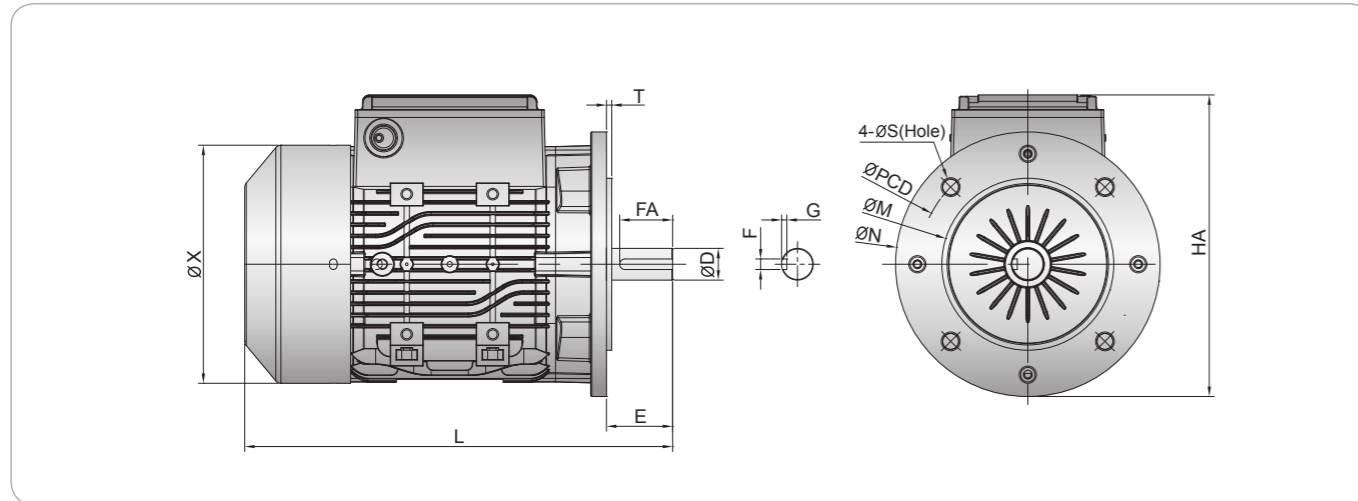

Dimensions

Frame Size	Output (kW)			Dimension(mm)													Bearings	
				Overall							DE Shaft extension							
	2P	4P	6P	S(Hole)	PCD	M	N	HA	L	X	T	D	E	F	FA	G	DE	ODE
71M	0.4	*0.2		10	130	110	160	180	237	142	3	14	30	5	25	3	6203ZZ	6202ZZ
	*0.55	0.4																
80M			0.4	12	165	130	200	212	266	160	3.5	19	40	6	30	3.5	6204ZZ	6203ZZ
	0.75	*0.55																
	*0.9	0.75																
90L	1.5	*0.75	0.75	12	165	130	200	228	324	180	4	24	50	8	45	4	6205ZZ	6204ZZ
	2.2	*1.1																
		1.5																
100L		2.2	1.5	12	215	180	250	256	360	196	4	28	60	8	45	4	6206ZZ	6205ZZ
	*3																	

Note 1. 上記の仕様は、品質と性能を向上させるために予告なく変更されることがあります。
2. *表示はIEC/KS規格品ではありません。

单相誘導電動機 (全閉型)

コンデンサ運転型／コンデンサ起動&運転型

B35 Horizontal Vertical types



Dimensional drawings

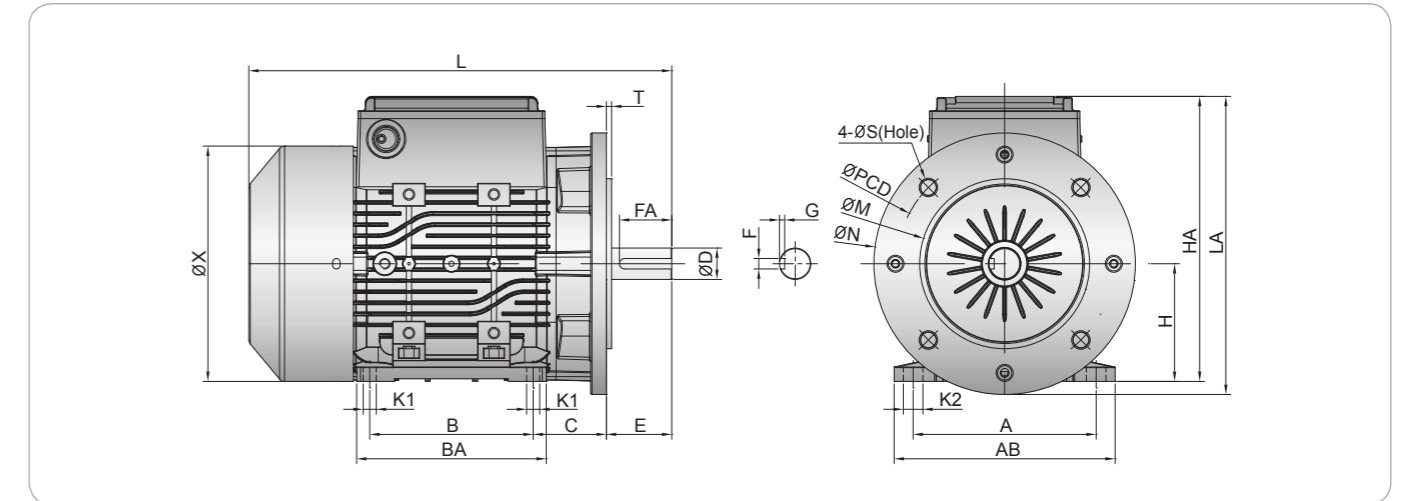

Dimensions

Frame Size	Output (kW)			Dimension(mm)																	Bearings						
				Overall							DE Shaft extension						Base										
	2P	4P	6P	S(Hole)	PCD	M	N	H	C	HA	LA	L	X	T	D	E	F	FA	G	A	B	AB	BA	K1	K2	DE	ODE
71M	0.4	*0.2		10	130	110	160	71	45	171	180	237	142	3	14	30	5	25	3	112	90	130	105	7	10	6203ZZ	6202ZZ
	*0.55	0.4																									
80M			0.4	12	165	130	200	80	50	192	212	266	160	3.5	19	40	6	30	3.5	125	100	149	130	10	15	6204ZZ	6203ZZ
	0.75	*0.55																									
	*0.9	0.75																									
90L	1.5	*0.75	0.75	12	165	130	200	90	56	218	228	324	180	4	24	50	8	45	4	140	125	169	145	10	15	6205ZZ	6204ZZ
	2.2	*1.1																									
		1.5																									
100L		2.2	1.5	12	215	180	250	100	63	231	256	360	196	4	28	60	8	45	4	160	140	190	165	12	15	6206ZZ	6205ZZ
	*3																										

Note 1. 上記の仕様は、品質と性能を向上させるために予告なく変更されることがあります。
2. *表示はIEC/KS規格品ではありません。

単相誘導電動機 (全閉型)

コンデンサ運転型／コンデンサ起動&運転型

B14 C-Face types



Dimensional drawings

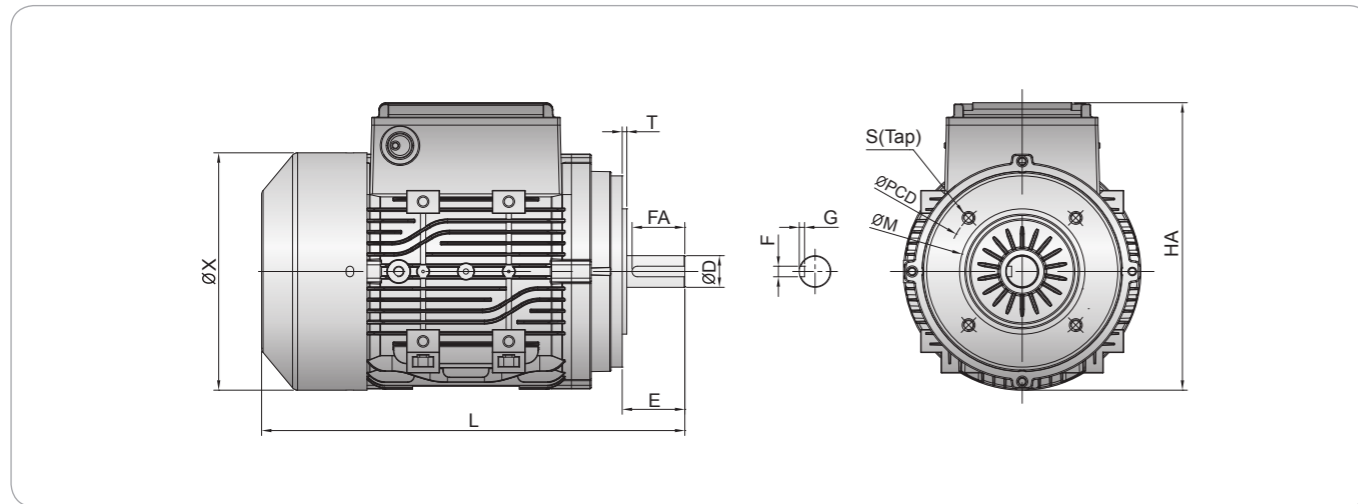

Dimensions

Frame Size	Output (kW)			Dimension(mm)												Bearings	
				Overall						DE Shaft extension							
	2P	4P	6P	S(Tap)	PCD	M	HA	L	X	T	D	E	F	FA	G	DE	ODE
71M	0.4	*0.2		M6	85	70	171	237	142	2.5	14	30	5	25	3	6203ZZ	6202ZZ
	*0.55	0.4															
80M			0.4	M6	100	80	192	266	160	3	19	40	6	30	3.5	6204ZZ	6203ZZ
	0.75	*0.55															
	*0.9	0.75															
90L	1.5	*0.75	0.75	M8	115	95	218	324	180	3.5	24	50	8	45	4	6205ZZ	6204ZZ
	2.2	*1.1															
100L		2.2	1.5	M8	130	110	231	360	196	3.5	28	60	8	45	4	6206ZZ	6205ZZ
	*3																

Note 1. 上記の仕様は、品質と性能を向上させるために予告なく変更されることがあります。
2. *表示はIEC/KS規格品ではありません。

単相誘導電動機 (全閉型)

コンデンサ運転型／コンデンサ起動&運転型

B34 Horizontal C-Face types



Dimensional drawings

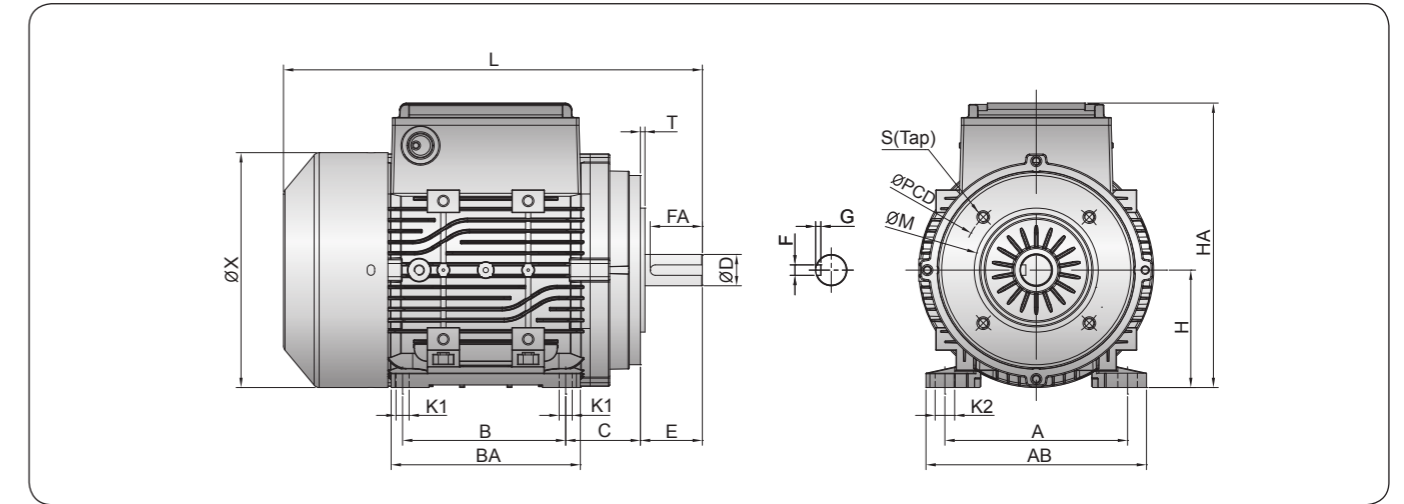

Dimensions

Frame Size	Output (kW)			Dimension(mm)															Bearings						
				Overall						DE Shaft extension					Base										
	2P	4P	6P	S(Tap)	PCD	M	H	C	L	HA	X	T	D	E	F	FA	G	A	B	AB	BA	K1	K2	DE	ODE
71M	0.4	*0.2		M6	85	70	71	45	237	237	142	2.5	14	30	5	25	3	112	90	130	105	7	10	6203ZZ	6202ZZ
	*0.55	0.4																							
80M			0.4	M6	100	80	80	50	266	266	160	3	19	40	6	30	3.5	125	100	149	130	10	15	6204ZZ	6203ZZ
	0.75	*0.55																							
	*0.9	0.75																							
90L	1.5	*0.75	0.75	M8	115	95	90	56	324	324	180	3.5	24	50	8	45	4	140	125	169	145	10	15	6205ZZ	6204ZZ
	2.2	*1.1																							
100L		2.2	1.5	M8	130	110	100	63	360	360	196	3.5	28	60	8	45	4	160	140	190	165	12	15	6206ZZ	6205ZZ
	*3																								

Note 1. 上記の仕様は、品質と性能を向上させるために予告なく変更されることがあります。
2. *表示はIEC/KS規格品ではありません。

04

油圧用誘導電動機

- ・三相プレミアム誘導電動機
Type : A/ C/ D
- ・単相誘導電動機
Type : A/ C/ D

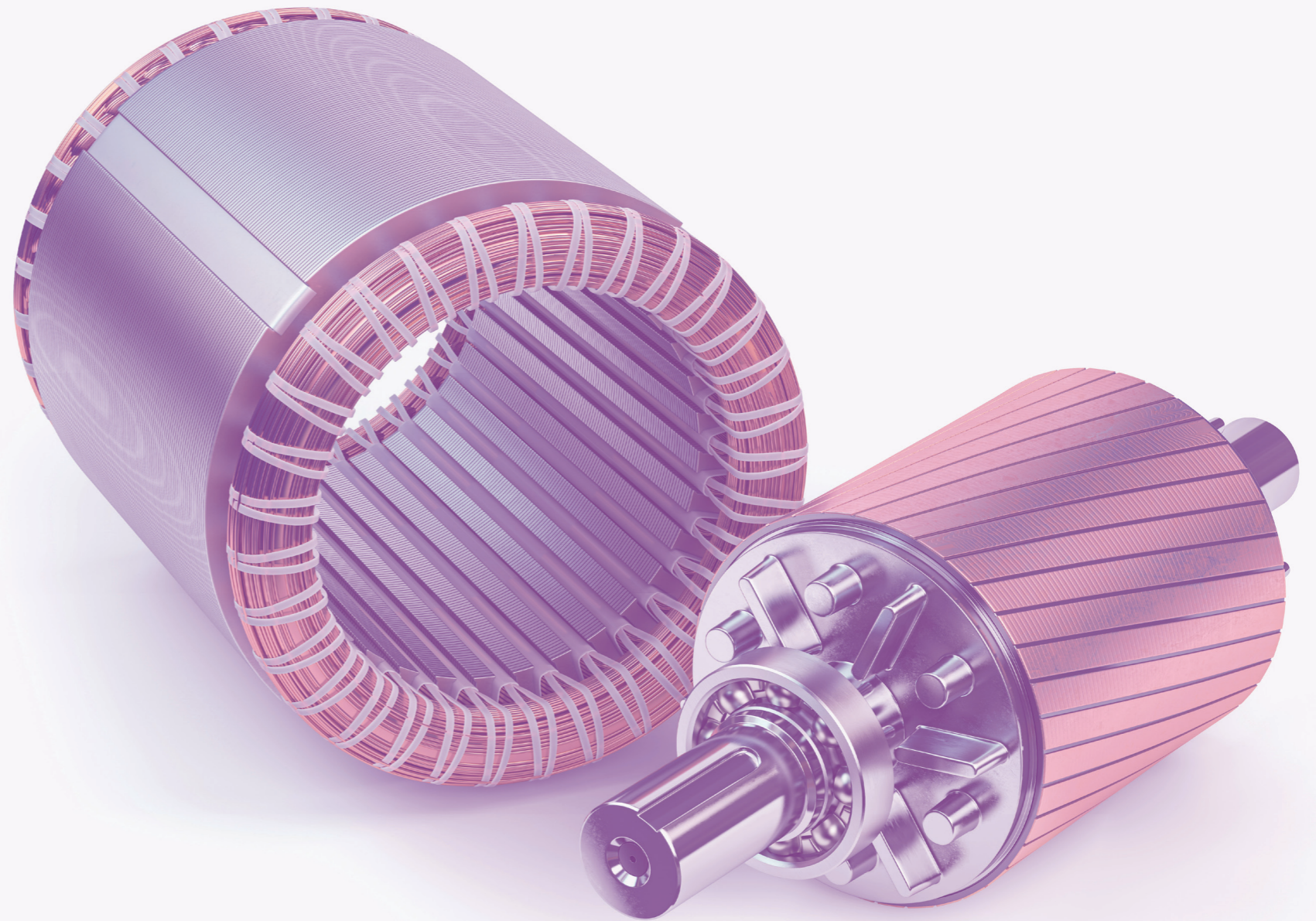

B34 Horizontal C-Face types

Dimensional drawings

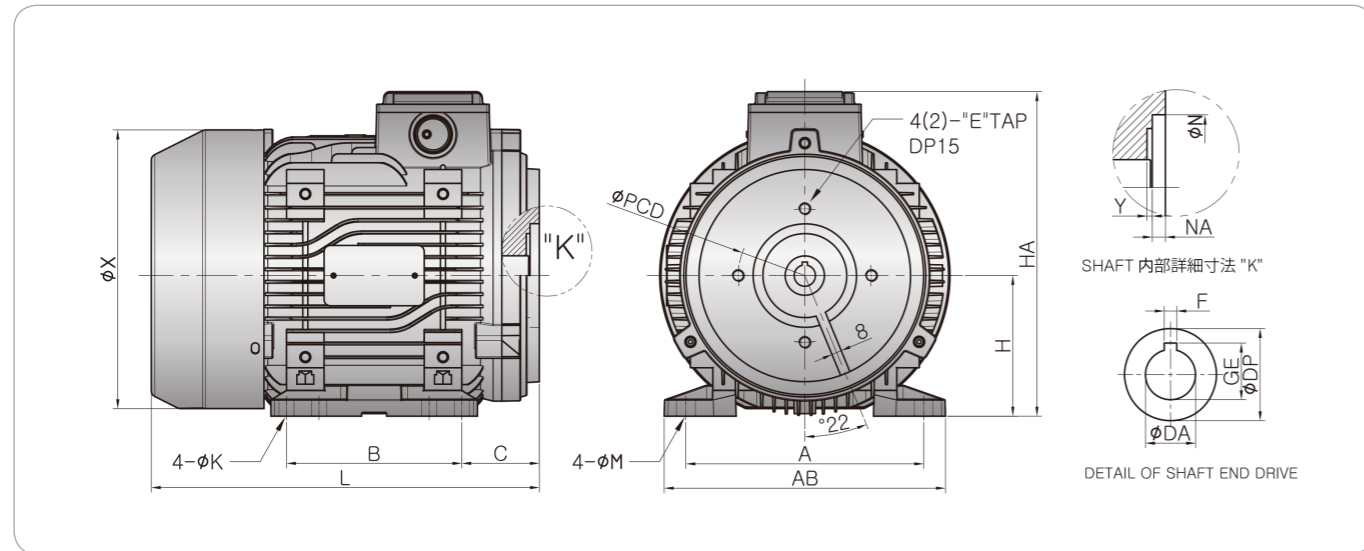

E/B TYPE(FRONT)

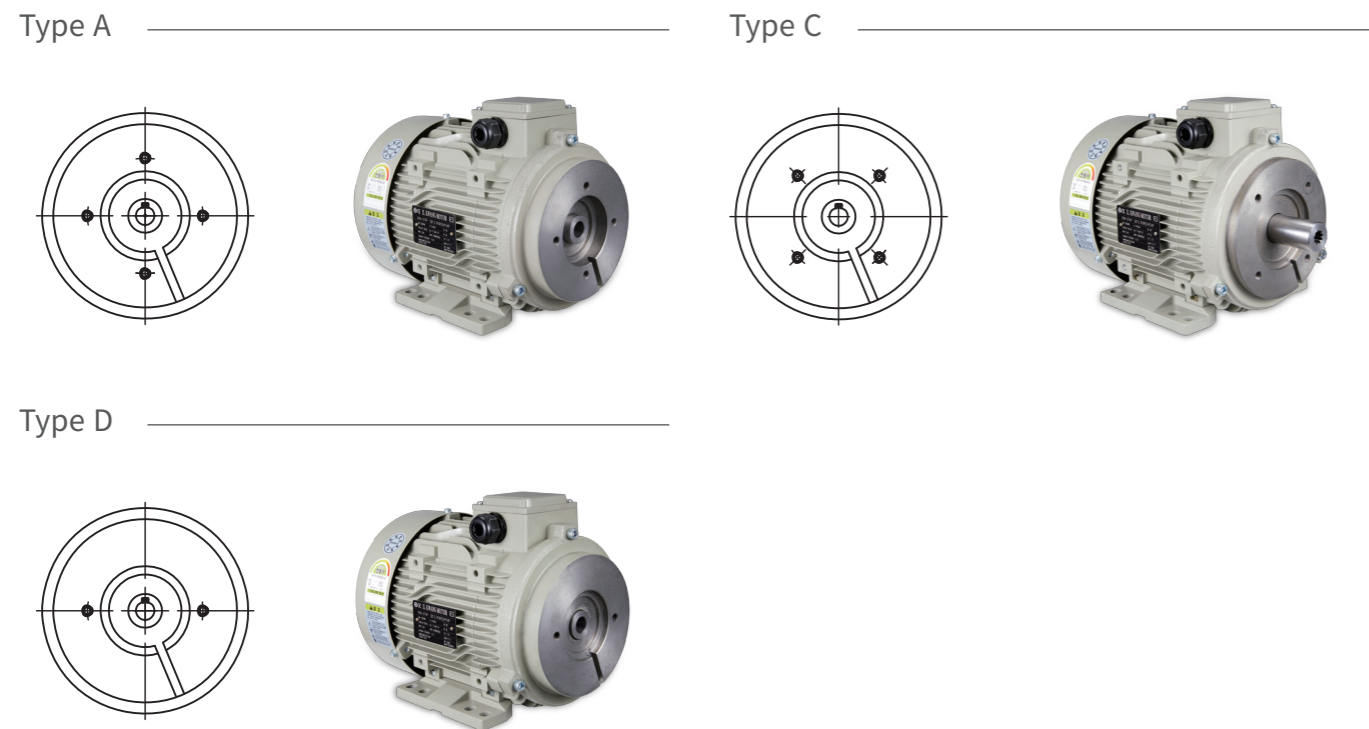

Dimensions

Frame Size	Model NO.	Output		Dimensions (mm)																Bearings(ZZ)						
		HP(KW) 4P	Type	Flange			TAP		ShaftT				A	AB	B	ØK	ØM	H	HA	ØX	C	L	DE	ODE		
				ØN	NA	Y	PCD	E	ØDA	GE	F	ØDP														
80M	IK307G1A0	1(0.75)	A	50.8	7.5	2	82.55	4-M8	12.7	14.3	3.2	29.7	125	149	100	10	15	80	189	160	55	232	6206	6203		
	IK307G1A1			50.8	8.5	2.5	82.55														56.5	233.5				
	IK307G1D0	1(0.75)	D	50.8	8.5	2.5	82.55	2-M8	56.5	233.5																
	IK307G2A0	1(0.75)	A	70	7	4	98	4-M8	15.88	18.7	5										55	232				
	IK307G3A0	1(0.75)	A	82.55	8.5	1	106.4	4-M10	15.88	17.7	4										55	232				
	IK307G3A1	1(0.75)	A	82.55	7.5	3.5	106.4	4-M10	12.7	14.3	3.2										56.5	233.5				
	IK307G3A2								15.88	17.7	4															
	IK307G3A3								19.05	21.4	4.76															
	IK307G3D0	1(0.75)	D	82.55	7.5	3.5	106.4	2-M10	12.7	14.3	3.2										56.5	233.5				
	IK307G3D1								15.88	17.7	4															
IK307G3D2	19.05	21.4	4.76																							
90L	IK315G1A0	2(1.5)	A	50.8	8.5	3	82.55	4-M8	12.7	14.3	3.2	29.7	140	169	125	10	15	90	212	180	55	272.5	6206	6204		
	IK315G1D0	2(1.5)	D	50.8	8.5	3	82.55	2-M8	12.7	14.3	3.2															
	IK315G3A0	2(1.5)	A	82.55	7.5	4	106.4	4-M10	12.7	14.3	3.2															
	IK315G3A1								15.88	17.7	4															
	IK315G3A2								19.05	21.4	4.76															
	IK315G3D0	2(1.5)	D	82.55	7.5	4	106.4	2-M10	12.7	14.3	3.2															
	IK315G3D1								15.88	17.7	4															
	IK315G3D2	19.05	21.4	4.76																						
	IK315G4C0	2(1.5)	C	95.05	7	4.5	127	4-M10	19.05	21.4	4.76														63	303
	100L	IK322G1A0	3(2.2)	A	50.8	8.5	4.5	82.55	4-M8	12.7	14.3														3.2	29.7
IK322G1D0		3(2.2)	D	50.8	8.5	4.5	82.55	2-M8	12.7	14.3	3.2															
IK322G3A0		3(2.2)	A	82.55	12	1	106.4	4-M10	12.7	14.3	3.2															
IK322G3A1									15.88	17.7	4															
IK322G3A2									19.05	21.4	4.76															
IK322G3D0		3(2.2)	D	82.55	12	1	106.4	2-M10	12.7	14.3	3.2															
IK322G3D1									15.88	17.7	4															
IK322G3D2		19.05	21.4	4.76																						
IK322G4C0		3(2.2)	C	95.05	12	1	127	4-M10	12.7	14.3	3.2	61.5	301.5													
IK322G4C1									15.88	17.7	4															
IK322G4C2	19.05								21.4	4.76																
IK322G4C3	19.05								20.7	3.2																
IK322G4C4	19.05	21.4	4.76																							
112M	IK337G3D0	5(3.7)	D	82.55	7.5	3	106.4	2-M10	12.7	14.3	3.2	34.5	190	225	140	12	15	112	259	222	62	310	6207	6205		
	IK337G3D1								16	17.8	4															
	IK337G3D2	19.05	21.4	4.76																						
	IK337G3A0	5(3.7)	A	82.55	7.5	1	106.4	4-M10	15.88	17.7	4										60	308				
	IK337G3A1								19.05	21.4	4.8															
	IK337G4C0								19.05	20.7	3.2															
	IK337G4C1	19.05	21.4	4.76																						
	IK337G3D3	5(3.7)	D	82.55	8	4	106.4	2-M10	15.88	17.7	4										70.5	318.5				
	IK337G3D4								12.7	14.3	3.2															
	IK337G3D5								15.88	17.7	4															
IK337G3D6	19.05								21.4	4.76																
IK337G5D0	5(3.7)	D	101.6	10.5	1.5	146	2-M12	22.22	25.4	6.35	72	320														
132S	IK355G5A0	7.5(5.5)	A	101.6	10.5	3.5	146	4-M12	22.23	25.4	6.35	39.5	216	248	140/178	13	15	132	294	263	85.5	389	6308	6307		
	IK355G5D0		D	127	10	4	181	2-M16	31.77	35.4	7.98	44.5									6309					
132M	IK375G3A0	10(7.5)	A	82.55	10.5	1	106.4	4-M10	15.88	17.7	4	39.5	216	248	140/178	13	15	132	294	263	83	386.5	6308	6307		
	IK375G5A0		A	101.6	10.5	1	146	4-M12	22.22	25.1	6.35										83	386.5	6308			

Note | 上記の仕様は、品質と性能を向上させるために予告なく変更されることがあります。

B34 Horizontal C-Face types

Dimensional drawings

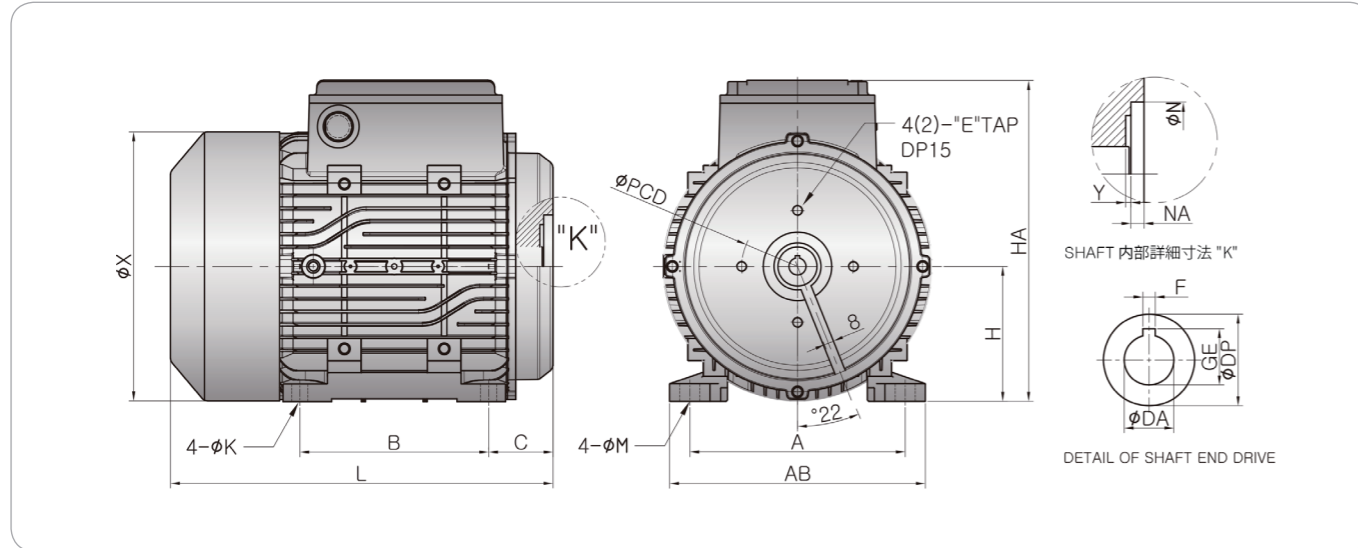

E/B TYPE(FRONT)

Type A _____ Type C _____

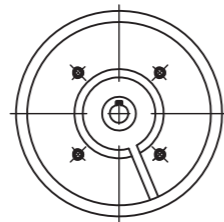
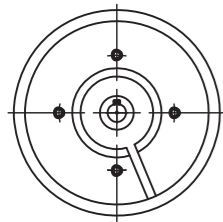

Type D _____

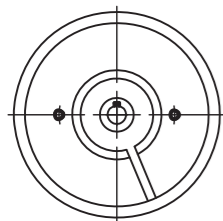

Dimensions

Frame Size	Model NO.	Output HP(KW) 4P	TYPE	Dimensions (mm)																Bearings (ZZ)				
				Flange			Tap		Shaft				A	AB	B	ØK	ØM	H	HA	ØX	C	L	DE	ODE
				ØN	NA	Y	PCD	E	ØDA	GE	F	ØDP												
80M	IK107G1A0	1(0.75)	A	50.8	8.5	2.5	82.55	4-M8	12.7	14.3	3.2	29.7	125	149	100	10	15	80	192	160	60	237	6206	6203
	IK107G1D0		D					2-M8																
	IK107G2A0	1(0.75)	A	82.55	7.5	3.5	106.4	4-M10	12.7	14.3	3.2													
	IK107G2A1							15.88	17.7	4														
	IK107G2A2							19.05	21.4	4.76														
	IK107G2D0							D	4-M10	12.7	14.3													
	IK107G2D1	1(0.75)	D	82.55	7.5	3.5	106.4	4-M10	15.88	17.7	4													
	IK107G2D2							19.05	21.4	4.76														
90L	IK115G1A0	2(1.5)	A	50.8	8.5	2.5	82.55	4-M8	12.7	14.3	3.2	29.7	140	169	125	10	15	90	218	180	60	277.5	6206	6204
	IK115G1D0		D					2-M8																
	IK115G2A0	2(1.5)	A	82.55	7.5	3.5	106.4	4-M10	12.7	14.3	3.2													
	IK115G2A1							15.88	17.7	4														
	IK115G2A2							19.05	21.4	4.76														
	IK115G2D0							D	4-M10	12.7	14.3													
	IK115G2D1	2(1.5)	D	82.55	7.5	3.5	106.4	2-M10	15.88	17.7	4													
	IK115G2D2							19.05	21.4	4.76														
100L	IK122G1A0	3(2.2)	A	50.8	8.5	2.5	82.55	4-M8	12.7	14.3	3.2	29.7	160	190	140	12	15	100	238	199	63	303	6206	6205
	IK122G1D0		D					2-M8																
	IK122G2A0	3(2.2)	A	82.55	12	1	106.4	4-M10	12.7	14.3	3.2													
	IK122G2A1							15.88	17.7	4														
	IK122G2A2							19.05	21.4	4.76														
	IK122G2D0							D	4-M10	12.7	14.3													
	IK122G2D1	3(2.2)	D	82.55	12	1	106.4	2-M10	15.88	17.7	4													
	IK122G2D2							19.05	21.4	4.76														

Note | 上記の仕様は、品質と性能を向上させるために予告なく変更されることがあります。

05

オンデマンド 誘導電動機

- ・ 単相誘導電動機 (半閉型)
- ・ ポンプ用
- ・ 減速機用
- ・ 空調、ファン、送風機用
- ・ 産業機械用
- ・ NEMA標準

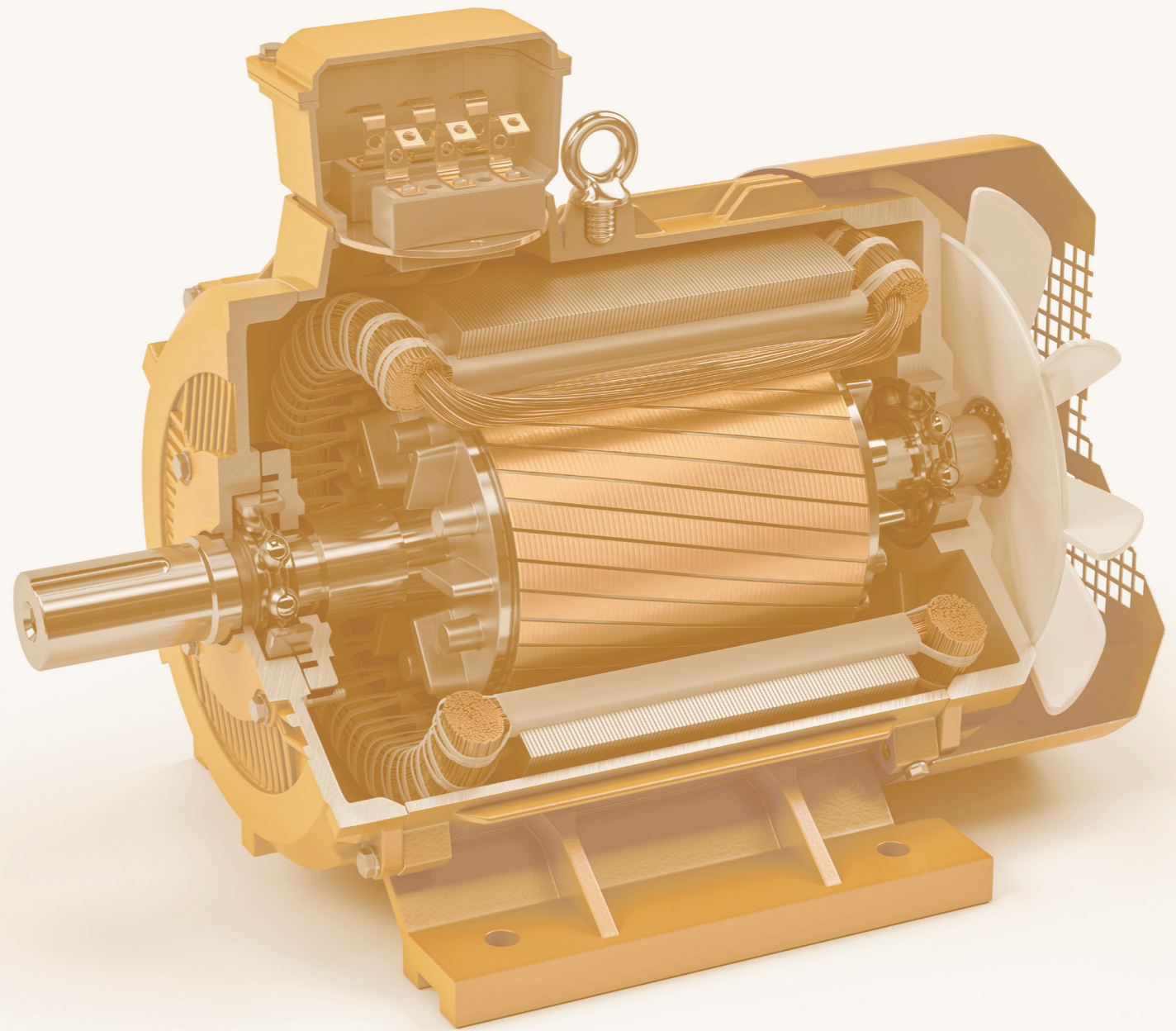

オンデマンド単相誘導電動機 (半閉型)

B3 Horizontal types



Dimensional drawings

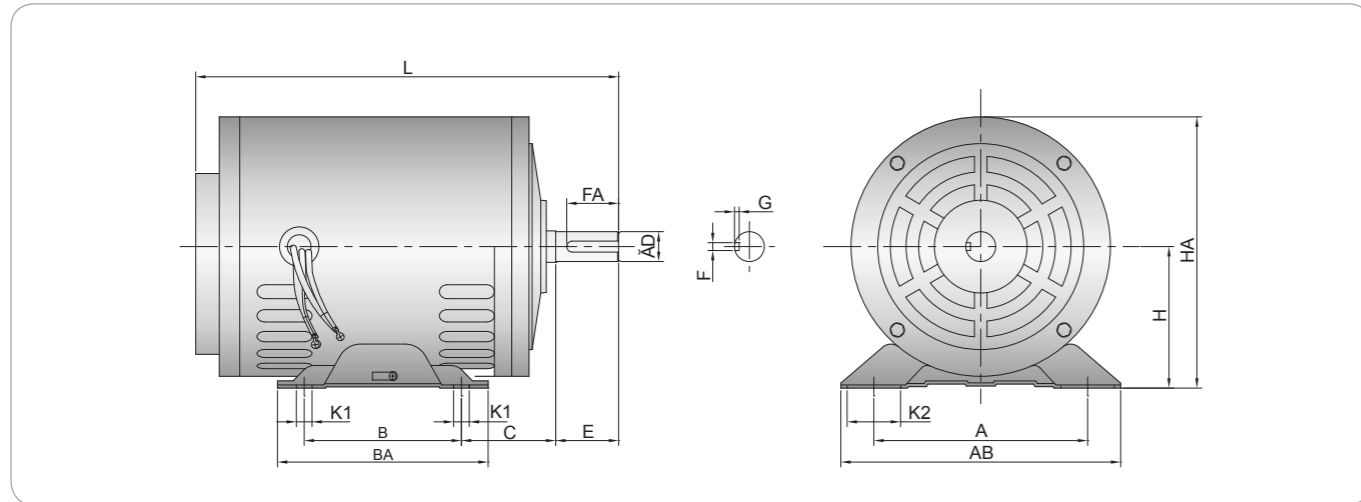

Dimensions

Frame Size	Output (kW)	Dimensions (mm)																	Bearings	
		Overall					DE Shaft extension					Base								
	2P	4P	H	C	L	HA	D	E	F	FA	G	A	B	AB	BA	K1	K2	DE	ODE	
73		*0.2	73	52	233	139	14	30	5	20	3	112	90	150	110	7	18	6202	6202	
79		*0.4	79	47	266	162	19	40	5	30	3	125	100	165	130	10	30	6204	6203	
90L		*0.4	90	60	269	173	19	40	5	33	3	136	100	178	134	10	34	6204	6203	
		*0.75	90	53	290	173	19	40	6	30	3.5	140	125	190	155	10	30	6204	6203	
106		*0.75	106	71	336	212	22	50	7	40	4	169	114	228	150	11	35	6205	6203	
		*1.5	106	72.5	355	212	28	60	7	50	4	169	114	228	150	11	35	6206	6203	
		*2.2	106	70	370	212	28	60	7	50	4	169	114	228	150	11	35	6206	6203	
116		*1.1	106	70	335	212	22	50	7	40	4	167	114	228	150	11	35	6205	6203	
		*1.5	116	61	360	229	28	60	7	50	4	167	142	234	180	11	34	6206	6204	
		*2.2	116	65	376	229	28	60	7	50	4	167	142	234	180	11	34	6206	6204	
	*3.7	116	67	406	229	28	60	7	50	4	167	142	234	180	11	34	6206	6204		

Note | 1. 上記の仕様は、品質と性能を向上させるために予告なく変更されることがあります。
2. *表示はIEC/KS規格品ではありません。

オンデマンド誘導電動機

ポンプ用



定数：3Ø
極数：2, 4
出力：0.2 ~ 18.5kW
電圧：220/380V AC, 380V AC
周波数：60 Hz, 50 Hz

減速機用

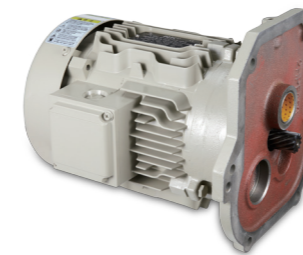

定数：3Ø
極数：4
出力：0.2 ~ 7.5kW
電圧：220/380V AC
周波数：60 Hz, 50 Hz

空調、ファン、送風機用

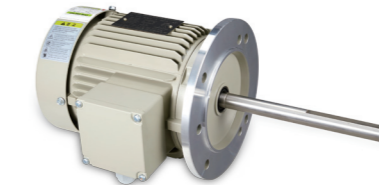

定数：3Ø, 1Ø
極数：2, 4, 6
出力：0.2 ~ 18.5kW
電圧：220/380V AC, 220V AC
周波数：60 Hz, 50 Hz

産業機械用



定数：3Ø
極数：2, 4, 6
出力：0.2 ~ 15kW
電圧：220/380V AC
周波数：60 Hz, 50 Hz

NEMA標準

別途注文生産します

Note | オンデマンド/非規格品については、当社営業部にお問い合わせください。

06

送風機

- ・遠心型高圧送風機
- ・遠心型ターボ送風機

遠心型高圧送風機

- ・アルミケーシング (Casing)
- ・設置・方向転換が容易
- ・低騒音・高効率
- ・固定圧、大風量ファン



Dimensional drawings

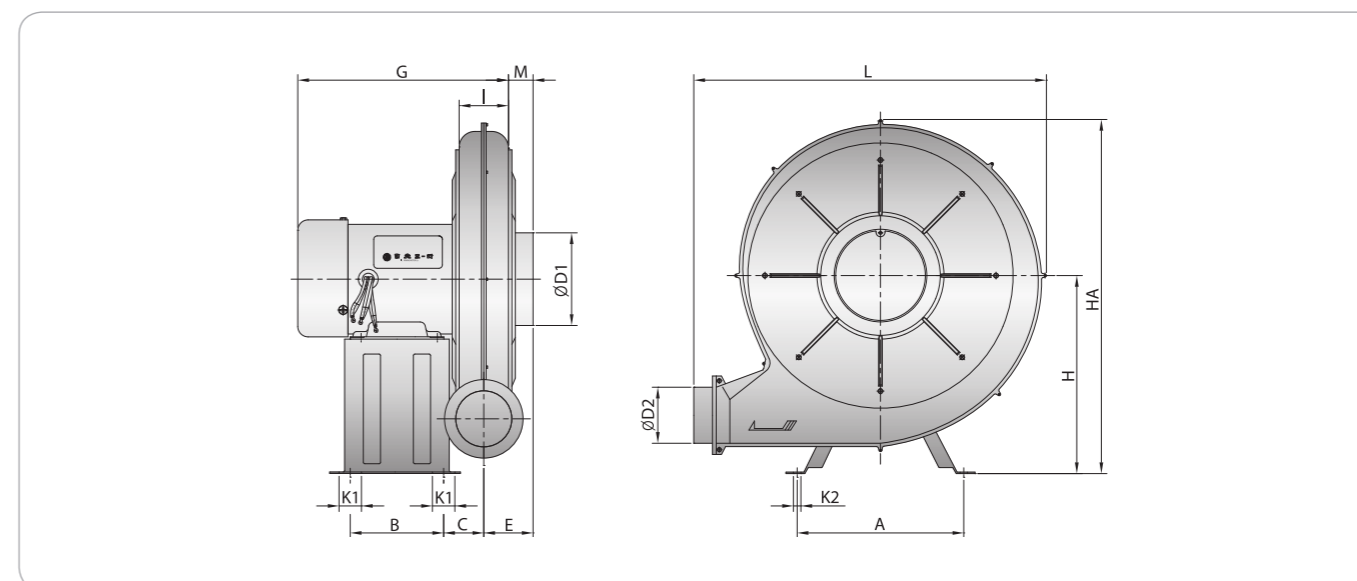

Technical Specification

Phase	Power (kW)	Pole	Voltage (V)	Current (A)	Frequency (Hz)	Static Pressure (mmAq)	Wind Capacity (m3/min)	Speed (RPM)	Duty	Protection
1Ø	0.75	2	220	4.5	60	314	8	3,450	S1	ODP
3Ø	0.75	2	380/220	3.5/2.0	60	314	8	3,450	S1	ODP, TEFC

Dimensions

Model NO	Dimension(mm)													
	A	B	C	E	K1	K2	D1	D2	I	M	G	L	H	HA
IKM-HF-0.75S	223	125	46	66	30	8	124	75	66	33	282	472	260	474
IKM-HF-0.75T														

Note | 上記の仕様は、品質と性能を向上させるために予告なく変更されることがあります。

遠心型ターボ送風機

- ・設置と方向転換が容易
- ・低騒音・高効率
- ・固定圧、大風量ファン



Dimensional drawings

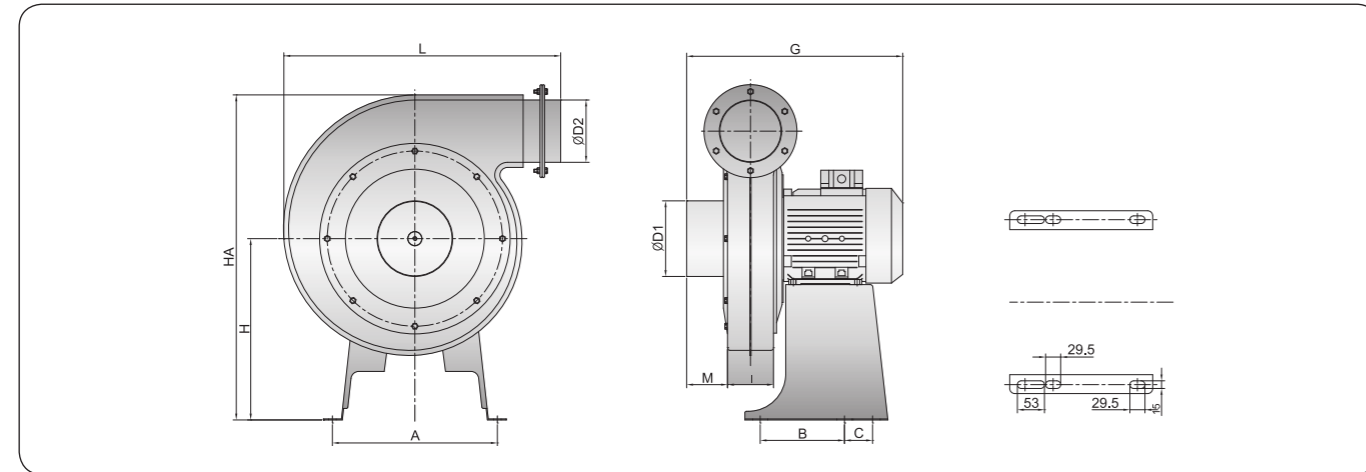

Technical Specification

Phase	Power (kW)	Pole	Voltage (V)	Current (A)	Frequency (Hz)	Static Pressure (mmAq)	Wind Capacity (m3/min)	Speed (RPM)	Duty	Protection
1Ø	0.75	2	220	3.9	60	265	26	3,450	S1	IP55
1Ø	1.5	2	220	4.5	60	285	40	3,450	S1	IP55
1Ø	2.2	2	220	8.2	60	320	52	3,450	S1	IP55
3Ø	0.75	2	380/220	3.9/2.4	60	265	26	3,450	S1	IP55
3Ø	1.5	2	380/220	7.5/4.5	60	285	40	3,450	S1	IP55
3Ø	2.2	2	380/220	8.2/4.8	60	320	52	3,450	S1	IP55
3Ø	3.7	2	380/220	13/7.6	60	380	63	3,450	S1	IP55

Dimensions

Model NO	Dimension(mm)										
	A	B	C	D1	D2	I	M	G	L	H	HA
IKM-TF-0.75S	315	165	55	143	123	90	70	390	530	345	616
IKM-TF-0.75T	315	165	55	143	123	90	70	390	530	345	616
IKM-TF-1.5S	323	165	55	148	122	90	80	423	542	355	637
IKM-TF-1.5T	323	165	55	148	122	90	80	423	542	355	637
IKM-TF-2.2S	323	165	55	195	150	110	56	420	616	355	663
IKM-TF-2.2T	323	165	55	195	150	110	56	420	616	355	663
IKM-TF-3.7T	323	165	55	195	150	110	56	463	616	377	685

Note | 上記の仕様は、品質と性能を向上させるために予告なく変更されることがあります。

07 結線図 / 重量

三相誘導電動機結線図

単電圧 (Single Voltage)	3ストランド引き出し		6ストランド引き出し			正転: CW
	直入起動 (D.O.L.starting)		Y起動 (Y-Starting)	△起動 (△-Starting)		
	1 2 3 L1 L2 L3		6-4-5 1 2 3 L1 L2 L3	6 4 5 1 2 3 L1 L2 L3		1 2 3 L1 L2 L3
正電圧 (Dual Voltage)	低電圧 220V (△結線)			高電圧 380V (Y結線)		逆回転: CCW
	6 4 5 1 2 3 L1 L2 L3	Y-△ 起動可能 結線は単電圧6本鎖 引き出し時と同じ	6-4-5 1 2 3 L1 L2 L3		Y-△ 起動不可	
配電圧 (Double Voltage)	9ストランド引き出し					
	低電圧 220V		高電圧 440V		高電圧 440V	
	4-5-6 7 8 9 1 2 3 L1 L2 L3	4 5 6 7 8 9 1 2 3 L1 L2 L3	7 8 9 6 4 5 1 2 3 L1 L2 L3		7 8 9 4 5 6 1 2 3 L1 L2 L3	
	モーター内部結線 (Y結線)			モーター内部結線 (△結線)		

単相誘導電動機結線図

	単電圧		正電圧	
	3ストランド引き出し	4ストランド引き出し	110V	220V
正転 (CW)	1 2 6 3 POWER	1 2 5 6 POWER	6 2 3 5 1 4 POWER	6 3 5 2 1 4 POWER COM
逆回転 (CCW)	1 2 6 POWER	1 2 6 5 POWER	5 2 3 6 1 4 POWER	5 3 6 2 1 4 POWER COM

電動機重量 [kg]

定数	極数	0.2kW	0.4kW	0.75kW	1.5kW	2.2kW	3.7kW	5.5kW	7.5kW	11kW*	15kW*	18.5kW*
三相	2	4.4	6.8	10.2	15.4	17.6	30.4	46	53	83	89	105
	4	7	7	14	16.5	25.8	30.4	50	56	95	99	

Note | 上記データはB3基準であり、B5時11~18.5kWはB3より5kg追加

定数	極数	0.2kW	0.4kW	0.75kW	1.5kW	2.2kW
単相	2	5.5	7.5	9.3	14	17.4
	4	6.9	9.2	12.7	18.6	26.6

08 主な証明書

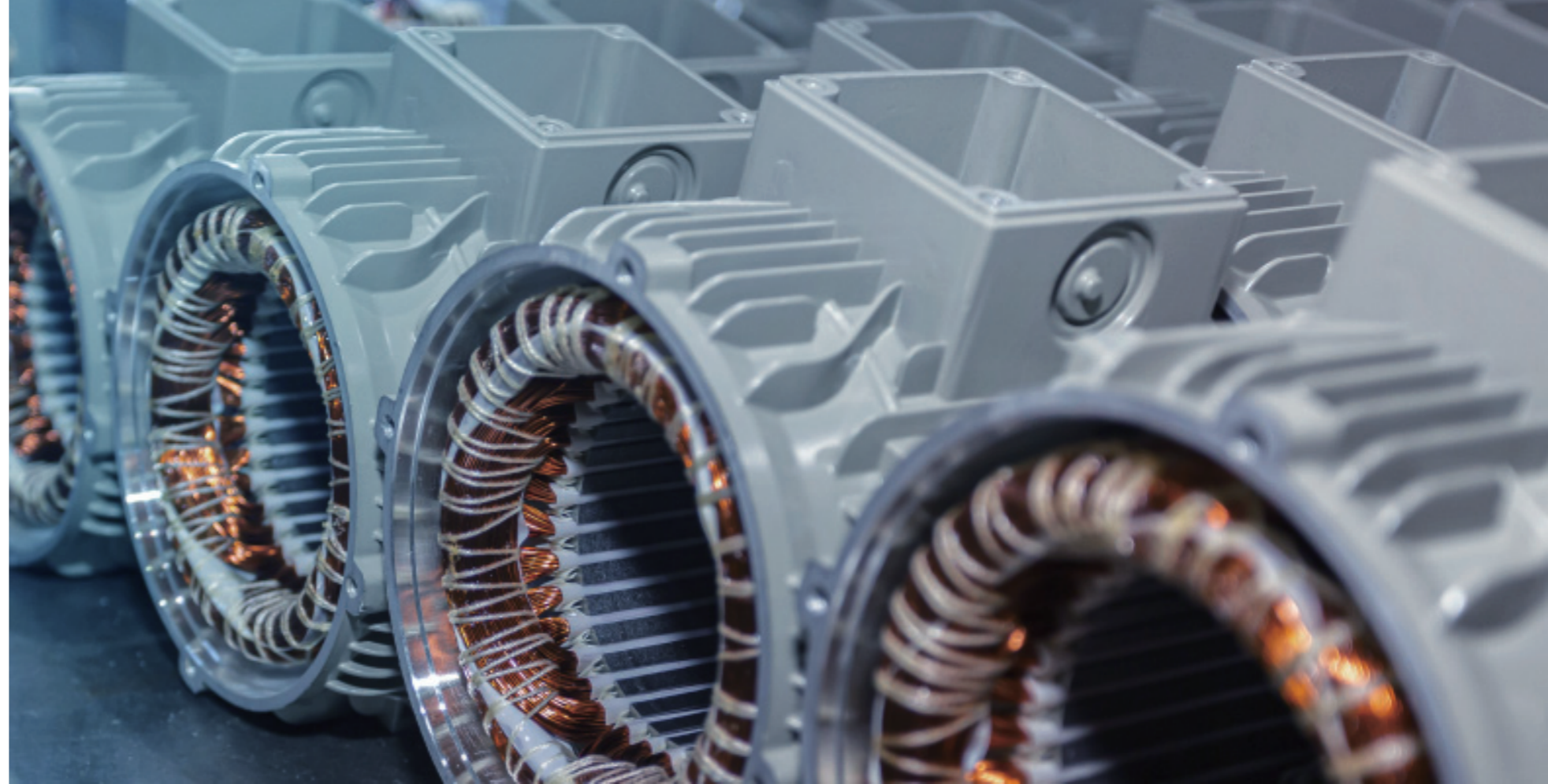

ベンチャー企業

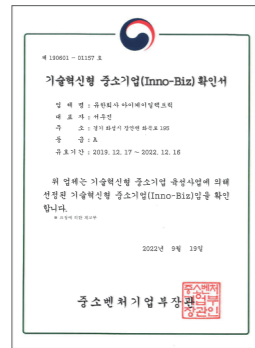

技術革新中小企業 (Inno Biz)

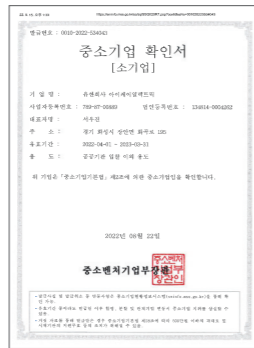

中小企業確認書



企業付設研究所

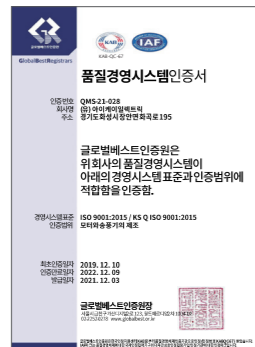

ISO 9001

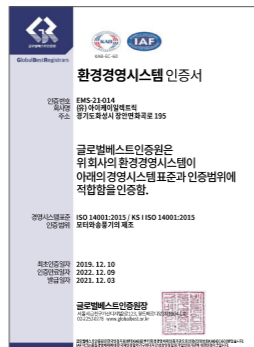

ISO 14001



品目別原産地認証輸出者 証明書



UL 認証 (CANADA)



特許証



特許証



UL 認証 (US)



CE 認証



KS 認証 (三相)

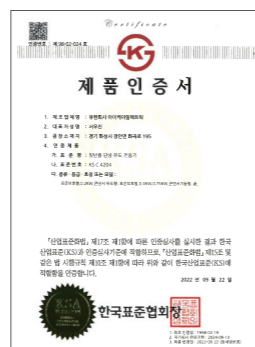

KS 認証 (单相)

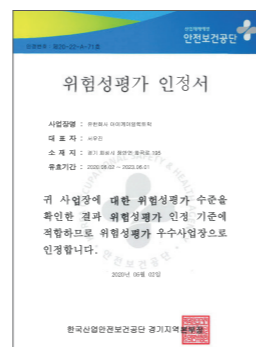

リスク評価



디자인登録証



디자인登録証

IK Electricは お客様の信頼のもとに、市場の変化に応じて 絶え間ない挑戦と革新を行い、世界一の企業になるために 最善の努力を尽くします。



www.ikelectric.co.kr

京畿道 華城市 長安面 禾谷路 195

Tel : +82-31-351-3750 Fax : +82-31-351-3753



CATALOG Copyright IK ELECTRIC / June 2023

日本連絡先